

FIG. NO. 355EC12 / ...



APPROVAL No. 01/01

APPLICATIONS

MODEL 355EC11/12 IS DESIGNED FOR CRITICAL SERVICE APPLICATIONS INVOLVING LETHAL, TOXIC, CORROSIVE, INFLAMMABLE, VOLATILE, RADIATING, OR EXPENSIVE FLUIDS.

THE MOST COMMON APPLICATIONS ARE

- **DRY CHLORINE (CL₂) SERVICE TEMPERATURE -40°C TO 120°C / -40°F TO 248°F**
- ANHYDROUS HYDROGEN CHLORIDE (HCL)
- ANHYDROUS HYDROFLUORIC ACID (HF)
- PHOSGENE (COCL₂)
- VINYL CHLORIDE MONOMER (VCM)
- ETHYLENE DICHLORIDE (EDC)
- ISOCYANITES (MDI, TDI, HDI, ETC.) AND
- FLUIDS OF SIMILAR NATURE.

MODEL 355EC11 (UP TO DN50/2") AND 355EC12 (>DN50/2) ARE EURO CHLOR APPROVED FOR THEIR COMPLIANCE WITH GEST 89/140. DESIGN AND SELECTED MATERIALS ALSO MEET THE REQUIREMENTS OF CHLORINE INSTITUTE PAMPHLET 6 SERVICE CLASSES I THROUGH VI. THE UNIQUE VALVE DESIGN GUARANTEES RELIABLE AND EXCELLENT PROTECTION AGAINST LEAKS OR FUGITIVE EMISSIONS. THE STEM SEAL REQUIRES VIRTUALLY NO MAINTENANCE DUE TO LEAK FREE WELD CONNECTIONS OF THE BELLOWS WITH BONNET AND STEM. CONSTANT PACKING MONITORING AND RE-PACKING IS ELIMINATED. IN THE UNLIKELY EVENT OF A BELLOWS FAILURE THE BACKUP PACKING GUARANTEES SAFE VALVE PERFORMANCE UNTIL THE NEXT SCHEDULED SHUTDOWN.

DESIGN FEATURES

BELLOWS AND PACKING

- BELLOWS PROTECTED IN EXTENDED BONNET AGAINST DIRECT IMPINGEMENT FROM PRODUCT FLOW
- MULTIPLE WALLS AND HYDROFORMED BELLOWS
- UP TO 50.000 BELLOWS OPERATIONS GUARANTEED

STEM

- ONE-PIECE STEM WITH OUTSIDE THREAD
- GUIDED STEM ON TOP AND BOTTOM

BODY AND BONNET

- BODIES ARE ONE-PIECE FORGINGS OR CASTINGS WITH LARGER THAN REQUIRED WALL THICKNESS AND INTEGRAL FLANGES
- EXTENDED BONNET PROVIDES FOR GOOD THERMAL INSULATION
- BODY BONNET JOINT GASKET IS FULLY CONFINED TO PREVENT GASKET FLOW OR BLOWOUT

SEATS

- SOLID HARDFACINGS FOR OUTSTANDING CORROSION AND WEAR RESISTANCE
- KNIFE EDGE METAL-TO-METAL SEAT FOR BUBBLE-TIGHT SHUTOFF
- REPLACEABLE DISC FOR INEXPENSIVE MAINTENANCE

= ZERO EMISSIONS, ZERO SEAT LEAKAGE, LOW MAINTENANCE



MODEL 355EC12

STRAIGHT WAY / PROTECTED BELLOWS

STANDARD MATERIALS OF CONSTRUCTION

FIG. NO. 355EC12 / ...

OPTIONS

OTHER MATERIALS PER CUSTOMER REQUIREMENTS ARE AVAILABLE!

NOTES

PHÖNIX RESERVES THE RIGHT TO CHANGE PRODUCT DESIGN AND SPECIFICATION WITHOUT NOTICE!

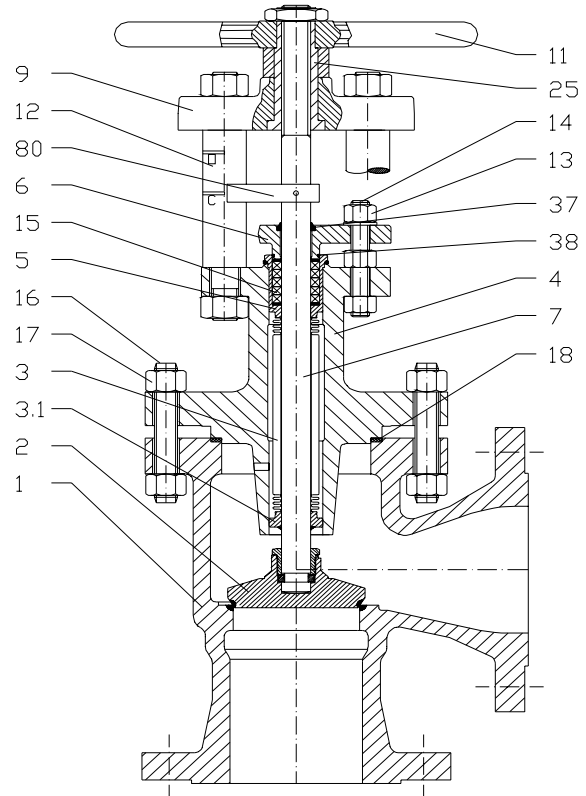

MATERIALS

ITEM	PART NAME	LOW TEMP. CARBON STEEL	LOW TEMP. CARBON STEEL
		-40°C up to 120°C	-40°F up to 248°F
1	BODY SEAT OVERLAY	1.1138 STELLITE 21 (≈ 32HRC)	A352 LCC STELLITE 21 (≈ 32HRC)
2	DISC OVERLAY	1.4571 / 1.0566 STELLITE 6 (≈ 42HRC)	A479 316Ti / A350 LF2 STELLITE 6 (≈ 42HRC)
3	BELLOWS	2.4819 ¹⁾	HASTELLOY C-276 ¹⁾
3.1	GUIDE RING	2.4819 ¹⁾	HASTELLOY C-276 ¹⁾
4	BONNET	1.0566 / 1.1138	A350 LF2 / A352 LCC
5	STUFFING BOX BODY	2.4819 ¹⁾	HASTELLOY C-276 ¹⁾
6	GLAND FOLLOWER	1.5638	A352 LC3
7	STEM	1.4571 ²⁾	A479 316Ti ²⁾
9	BRIDGE	1.4541	AISI F321
11	HANDWHEEL	CAST IRON	CAST IRON
12	PILLAR	1.4057	AISI 431
13	HEX. NUT	A194 GR. 4	A194 GR. 4
14	STUD BOLT	A320 GR. L7	A320 GR. L7
15	PACKING	PTFE-RINGS	PTFE-RINGS
16	STUD BOLT	A320 GR. L7	A320 GR. L7
17	HEX. NUT	A194 GR. 4	A194 GR. 4
18	GASKET	KAMMPROFIL / PTFE	KAMMPROFIL / PTFE
25	BUSHING	1.0718 / QPQ nitrided	A29 12L13 / QPQ nitrided
37	WIPER	EPDM	EPDM
38	O-RING	EPDM	EPDM

¹⁾ TRIM MATERIAL 1.4571 / 316Ti OPTIONAL

²⁾ STEM MATERIAL 2.4819 / HASTELLOY C-276 OPTIONAL

FIG. NO. 355EC12 / ...

TESTING / MARKING

- TEST AND DESIGN ACC. TO GEST 89/140, GEST 86/128, GEST 86/129
- TÜV APPROVED STRENGTH CALCULATION ACC. TO DIN EN12516-2 AVAILABLE FOR BODY & BONNET
- STANDARD TESTS ACC. TO DIN EN12266, ISO 5208, RESISTANCE AND LEAK TEST ACC. TO ITEM BA/BQ
- LEAK TEST ON CLOSURE ACC. TO ITEM BO/BN (LEAKAGE RATE 1 = TIGHT)
- ASME B16.34 / MSS SP 61 / API 598 / BS 6755

PRESERVATION

- DRYING AT A TEMPERATURE OF 120°C (248°F) FOR AT LEAST 3 HOURS
- STUFFING OF DRYING AGENTS (SILICAGEL) INTO THE VALVE
- BLANKING OF INLET AND OUTLET ORIFICE WITH SUITABLE GASKETS AND BOLTED FLANGES TO AVOID ENTRY OF MOISTURE INTO THE VALVE
- DISC SECURED IN CLOSED POSITION
- UNFINISHED SURFACES PROTECTED AGAINST RUST
- LUBRICATION WITH CHLOROFLUORINATED GREASE

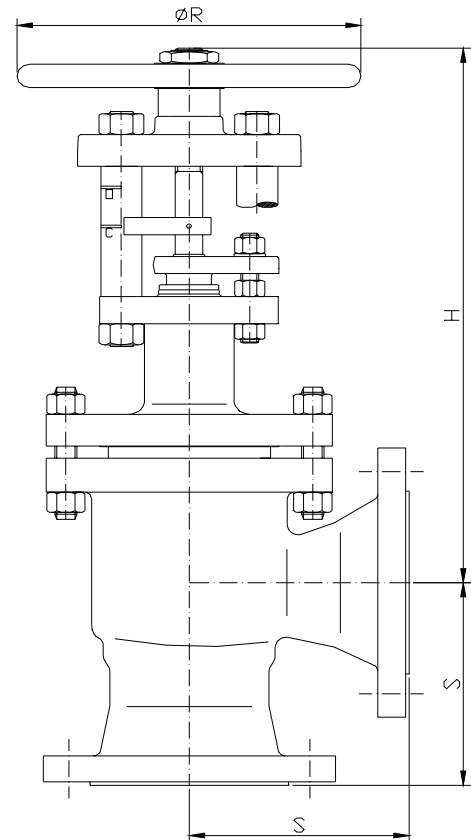

DIMENSIONS & WEIGHTS & FLOW COEFFICIENTS

DN	NPS	UNIT	S DIN	S ASME	H	ØR	WEIGHT	Kv [m³/h] cv [USGal/min]
80	3"	[MM]	155	159	545	250	56 kg	124
		[IN]	6.1	6.3	21.5	9.8	123 lbs	144
100	4"	[MM]	175	178	610	315	92 kg	197
		[IN]	6.9	7	24	12.4	202 lbs	229
150	6"	[MM]	225	222	840	400	192 kg	445
		[IN]	8.9	8.7	33.1	15.7	422 lbs	516

- OTHER SIZES ON REQUEST

PHÖNIX - POLE POSITION IN BELLOWS SEALED TECHNOLOGY

PHÖNIX WAS ESTABLISHED AT THE BEGINNING OF LAST CENTURY IN 1910 IN FRANKFURT, GERMANY AS SMALL, PRIVATELY OWNED COMPANY. SINCE 1955 PHÖNIX IS WIDELY KNOWN FOR ITS HIGH QUALITY BELLOWS SEALED VALVES FOR SEVERE HAZARDOUS CHEMICAL SERVICES.



THROUGHOUT THE NEARLY ONE HUNDRED YEARS OF ITS EXISTENCE, PHÖNIX HAS ALWAYS STRIVEN TO DEVELOP A PRODUCT LINE EXCEEDING EVEN THE MOST STRINGENT REQUIREMENTS OF THE INDUSTRY.

PHÖNIX OFFERS A COMPLETE LINE OF HIGH QUALITY, FIRST CLASS PRODUCTS THAT GUARANTEE LONG LASTING SAFETY AND RELIABILITY IN OUR CUSTOMERS' PLANTS.



GLOBALLY, PHÖNIX OFFERS ITS CUSTOMERS VALVES CONFIRMING TO NATIONAL AND INTERNATIONAL DESIGN STANDARDS SUCH AS DIN, ASME, GOST ETC. IN ADDITION PHÖNIX OFFERS TECHNICAL ADVICE AND SERVICE FOR COMPLETE VALVE PACKAGES. TOGETHER WITH OUR QUALIFIED ENGINEERING STAFF AND STATE OF THE ART MANUFACTURING FACILITY, WE PROVIDE HIGH QUALITY PRODUCTS TO ENSURE A LONG VALVE LIFETIME WITH HIGH PLANT SAFETY.